



TM

VENIERI
SPA

1.33C

4WS MINI LOADER
MINI BACKHOE LOADER





PARALLEL KINEMATIC

Efficient kinematics, able to guarantee high resistance to stress and an excellent parallel. The compact dimensions help to expand lateral visibility.



LED LIGHTS

LED work lights and lights ensure **superior visibility, reduced consumption and battery care.**



WHEELS AND STEERING

The machine **is very compact** thanks to the **4 driving and steering wheels** (optional "crab" steering) The **5.12" widened track** and **4.72" tyres** are able to offer **unbeatable stability** even during the **toughest uses.**



CABIN

It is common opinion that a sacrifice in terms of habitability is inevitable on compact machines. The new **XL cab** of the VF 1.33C, **widened by 5.91" from the jamb**, guarantees the operator optimal comfort and allows non-stop operation. Inside the cab you can find also ergonomic interiors with standard "all in 1" Joystick, armrests, footrests and cabin pressurization with internal air recirculation.



TOTAL STABILITY

Excellent stability in any situation, thanks to low center of gravity, track width widened and **oscillating front axle** (mechanically lockable - opt.)



MULTIFUNCTIONAL MACHINE

In addition to being an excellent front charger and a rear excavator, it is a **multifunctional machine** with a **high hydraulic flow**. Thanks to the universal attachments there are no limits to use countless equipments.

TIER 4f



53 HP JAPANESE TECHNOLOGY

The **Kubota** engine, **3 cylinders, turbo, electronic injection common-rail** is aligned with the latest regulations **Tier 4f** and delivers a high couple even at low revs.



TIRES FOR EVERY SIZE TYPE AND APPLICATION

Wide range of approved tires, specific for different use: both industrial and special work.



100% VENIERI DESIGN

Born in 1992, this model has undergone a decisive **evolution** over the years. Thanks to the Venieri Style Center, it has remained faithful to the **"family feeling"** while introducing notable items novelties in terms of **comfort** and **performance**, such as the new cabin livability.

1.33C

4-WHEEL STEERING BACKHOE "Z" KINEMATICS



DIESEL ENGINE

3 cylinder in line engine, turbocharged, common-rail injection with electronic control, exhaust gas recirculation EGR, water cooled, dry filtration, diesel oxidation catalyst (DOC), diesel particulate filter (DPF). Emissioned according to CE 97/68 - Tier 4f.

Type	Kubota D1803-CR-T
Max Power	39kW - 53 HP
Rated rpm	2,700
Rated Power Gross SAE J1995	37 kW - 50 HP
Rated Power Net SAE J1349	35,3 kW - 47 HP
Max torque	lbf ft 111
Bore	in 3.43
Stroke	in 4.03
Displacement	in ³ 111.43



ELECTRIC SYSTEM

Battery	12 Volt
Capacity EN 60095-1	80 Ah - 770 A
Alternator rating	60 A
Reverse warning	Standard
Wiring according to standards	IP 67 - DIN 40050



TRANSMISSION

Hydrostatic transmission with closed circuit automatic power regulation, variable - displacement pump and two forward/reverse speeds with electric single-lever control.

STD	Forward	Reverse
1 st Gear mph	0÷5	0÷5
2 nd Gear mph	0÷12	0÷12



AXLES

Designed for heavy duties, all wheel-drive. Automatic self-locking differentials. Planetary final drives in each wheel. Front axle: steering and oscillating up to a total angle of 15°. Rear axle: steering and fixed to the frame.



BRAKES

Service: disk brake hydraulically operating on front axle, working on all wheels.
Parking: mechanical drum brake operating on service brake, manually actuated.



TYRES

Standard	12 - 16.5
Optional	10 - 16.5 • 10.0/75 x 15.3



STEERING

Rigid frame with 4-wheel steering, servo-assisted hydraulic LOAD SENSING steering units.

Inner tyres turning radius	ft in 2'6.71"
External tyres turning radius	ft in 7'6.94"
External bucket turning radius	ft in 9'1.84"



HYDRAULIC SYSTEM

LOAD SENSING gear pump with priority valve for the steering circuit, modular three-element control valve for the loader, modular six-element control valve for the backhoe.

Double acting hydraulic cylinders. Hydraulic oil cooling radiator. Full-flow oil filter on the drain pipe.

Single cloche-lever "all in one" with 4 positions for lifting control and 3 positions for bucket control.

Max flow	gpm	14.27
Loader relief valve pressure	psi	3,046
Steering relief valve pressure	psi	2,031
Lift cylinders	in	3.54x17.91
Bucket cylinder	in	2.56x19.69



SERVICES CAPACITIES

Engine	gal	2.11
Front axle + gear box	gal	0.74
Rear differential	gal	0.53
Planetary gear	gal	0.05
Hydraulic circuit	gal	13.21
Brake system	gal	0.08
Fuel	gal	11.89
Water radiator	gal	2.91



TECHNICAL FEATURES

LOADER

Standard bucket capacity	yd ³	0.59
Standard bucket width	in	61.02
Breakout force	lb	5,512

BACKHOE LOADER

Type	VF	2.75
Standard bucket capacity	gal	11.89
Standard bucket width	in	11.81
Dipper stick max. penetration capacity	lb	3,086
Max breakout force on the bucket tip	lb	5,732
Lifting capacity on the bucket pin at the max.height	lb	1,543
Rotation		180°
A - Max. digging depth	ft in	9'0.27"
(Telesc./optional)	ft in	10'7.95"
B - Standard digging depth	ft in	8'6.36"
(Telesc./optional)	ft in	10'2.05"



DIMENSIONS AND WEIGHT

Max lenght in transfer (loader)	ft in	11'4.22"
Max. length in transfer (backhoe loader)	ft in	11'10.13"
Max. width in transfer	ft in	5'1.02"
Overall tyre width	ft in	4'11.06"
Wheel tracks width	ft in	4'0.62"
Ground clearance	ft in	10.43"
Standard operating weight (loader)	lb	6,614
Standard operating weight (backhoe loader)	lb	6,945
Max weight	lb	10,031

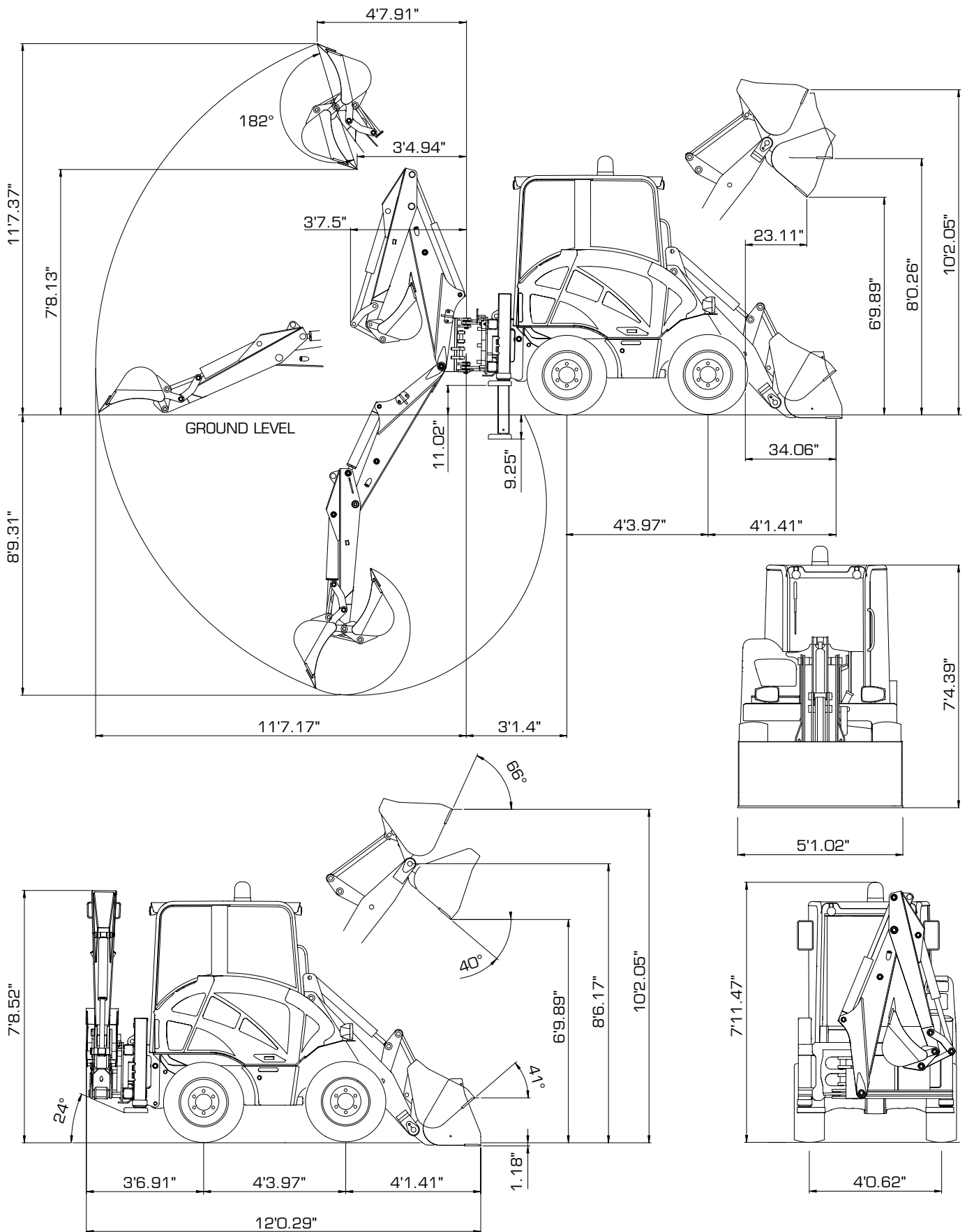

LOADING FORK (LB) Centre of gravity 1'7.69" ft in

Static tipping load - Full turn	3,197
Payload EN 474-3 (80%)	2,535
Payload EN 474-3 (60%)	1,918
Payload DIN 24094 (50 %)	1,598

LOADING BUCKET PERFORMANCE (LB)

Static tipping load - Full turn	4,409
Payload (50%)	2,205



MAINTENANCE

One of VF 1.33C profitability key factor is represented by the machine extremely reduced downtime. Therefore it has been designed to allow routine inspections to be made quickly and easily: just operate a simple catch to open the engine hood and everything's within your reach.

THE CABIN

Optimal accessibility, guaranteed by the reduced distance from the ground, the **total visibility** from the large 360° glasses, the ergonomic arrangement of the renewed instrumentation and a **driver's seat** with extremely large spaces for the category, make the cab of the new VF 1.33C an **optimal environment** where operate continuously.



BASIC MACHINE



Battery switch	•
Maintenance tool set	•
Fuel preheating (cold climates)	0
Cap with key for fuel tank	•
Self-locking proportional differential on the front axle	•
Self-locking proportional differential on the rear axle	0
Steering and oscillating front axle with 15°	•
Steering rear axle and fixed to chassis	•
Towing hook (anchoring and vehicle recovery, not towing equipment)	•
Rotating lamp	•
Soundproofing	•
User manual and Spare parts catalogue	•
Type approval for road circulation	•
Arm and bucket lock safety device	•
Device for bucket positioning parallel to the ground	•
Lever device for forward movement speed reduction	0
Floating arm system	•
Safety block valves on bucket cylinder	0
Safety block valves on lifting cylinder	0
“Venieri GLOBAL” system monitoring (Annual subscription not included)	0
Double-speed hydraulic fan	•
Reversible fan for radiator cleaning	-
Negative parking brake	-
Hydraulic service disk brake on rear axle	•
Inch pedal integrated on the brake pedal	•
Manual accelerator	•
Greasing points grouped on frames	-
Automatic centralized greasing system	-
LED Road lights front and rear	•
“Crab” steering	0
Water preheating system	0
Biodegradable hydraulic oil	0
Hydraulic oil ISO 46 (cold climates)	0
Vortex prefilter	0

CABIN EQUIPMENT



ROPS/FOPS 1st Level, pressurized and soundproofed	•
Canopy ROPS/FOPS I	0
Front and rear windshield wiper with washer	•
LED work lights (2 front + 2 rear)	•
Document compartment	•
Seat with mechanical suspension	•
Seat with pneumatic suspension	0
Seat armrests	-
Buzzer	•
Cabin carpet	•
Radio preparation	•
Supplementary socket 12V	•
Air Conditioning	0
Ceiling lamp	•
Sun visor	-
Rear view mirrors	•
Heatable rear view mirrors	-
First-aid kit	0
Fire extinguisher 4.41lb	0
Seat belt	•
Instrumentation and dashboard with LCD display	•
Safety glass breaker	0

MAIN EQUIPMENTS



FRONT / LOADER	
Hydraulic quick coupler	0
Mixing bucket	0
4-in-1 multipurpose bucket	0
High material bucket	0
Universal lifting forks	0
Shedder	0
Hydraulic brush cutter	0
Asphalt / concrete planner	0
Asphalt planner	0
Snow blower	0
Snow blade and “V” type snow blade	0
Hand operating hammer	0
Polishing brush	0
Sweeper	0
Trencher	0
High-tip bucket	0
High flow kit	0
Unpressurized return line	0
Double auxiliary line	0

REAR / BACKHOE LOADER	
Rear excavator arm STD	•
Rear arm locking system for travelling on the road	•
Telescopic rear arm	0
Rear excavator arm with hydraulic lateral translation	0
Hydraulic Hammer	0
Bidirectional hydraulic drill	0



www.venieriamerica.com



Via Piratello, 106 - 48022 Lugo (RA) - ITALY
Tel. +39 0545 904411 Fax +39 0545 30389
e-mail: info@vf-venieri.com | www.vf-venieri.com

Spare Parts
Tel. +39 0545 904429 Fax +39 0545 24555
e-mail: ricambi@vf-venieri.com